

View C-C

Bass Horn
by
Paul W. Klipsch

Designed by
J. P. Loring



28164

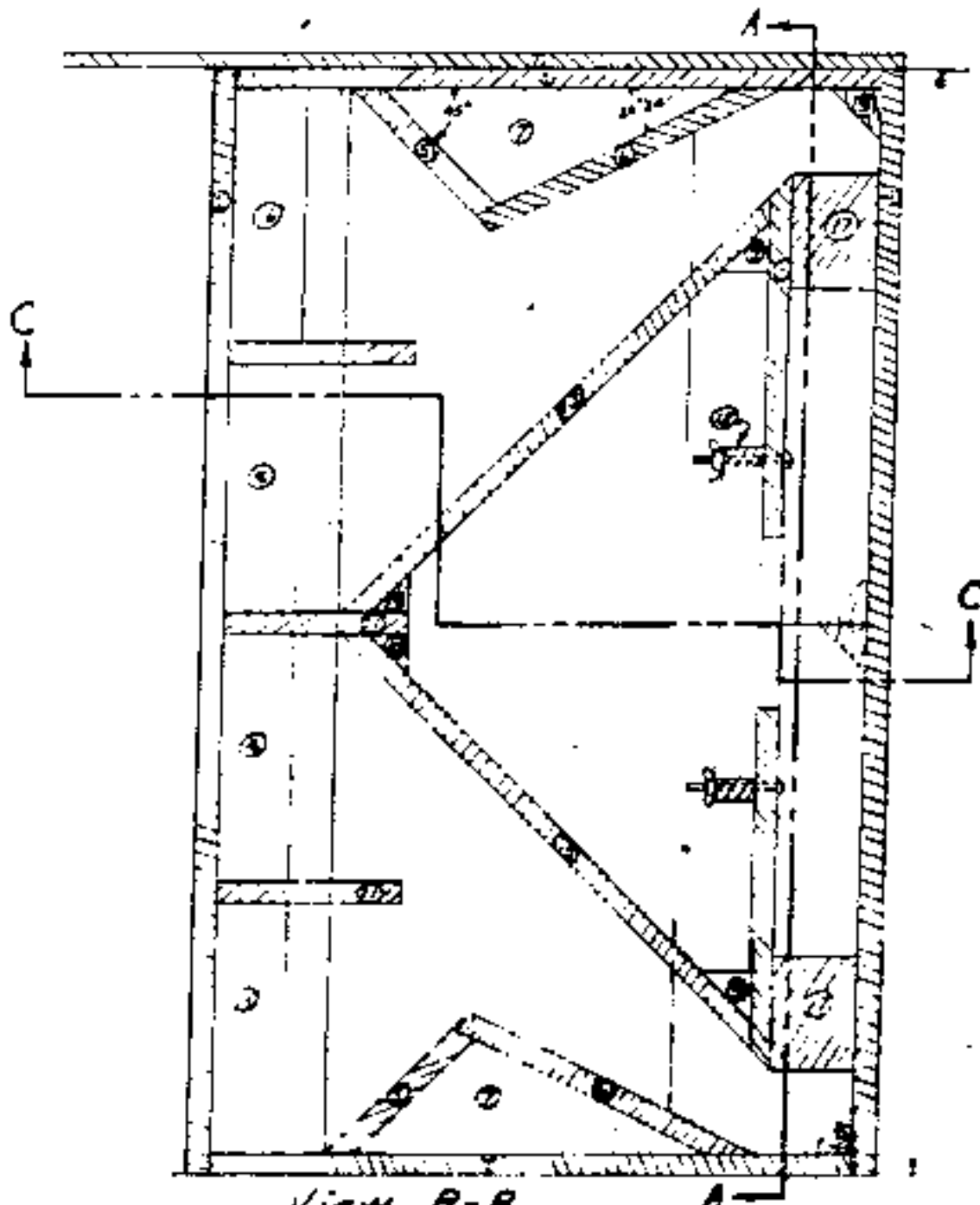

View B-B

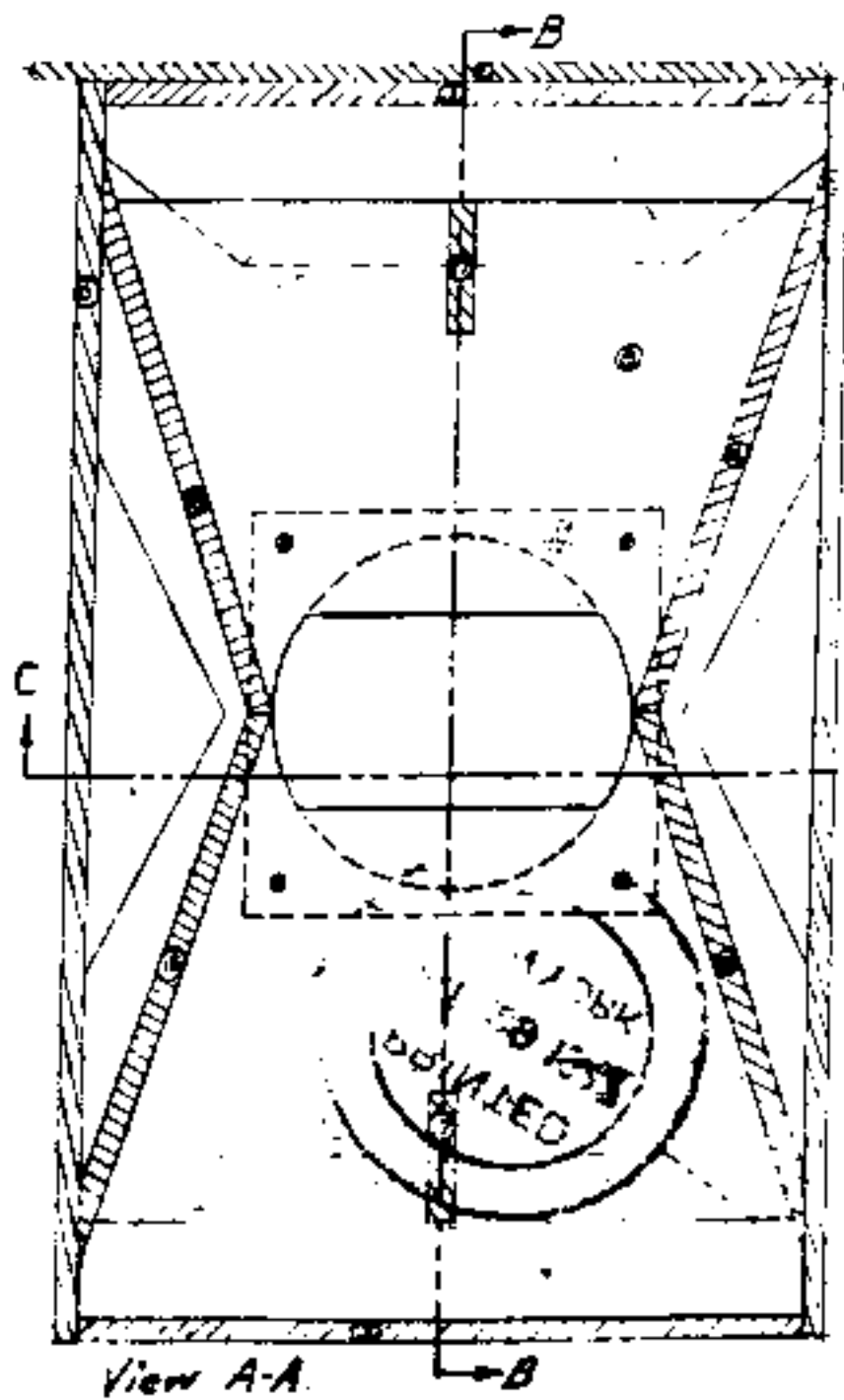

View A-A

Part No. 1 - 1 Rqd.

$\frac{1}{2}$ " or $\frac{3}{4}$ "

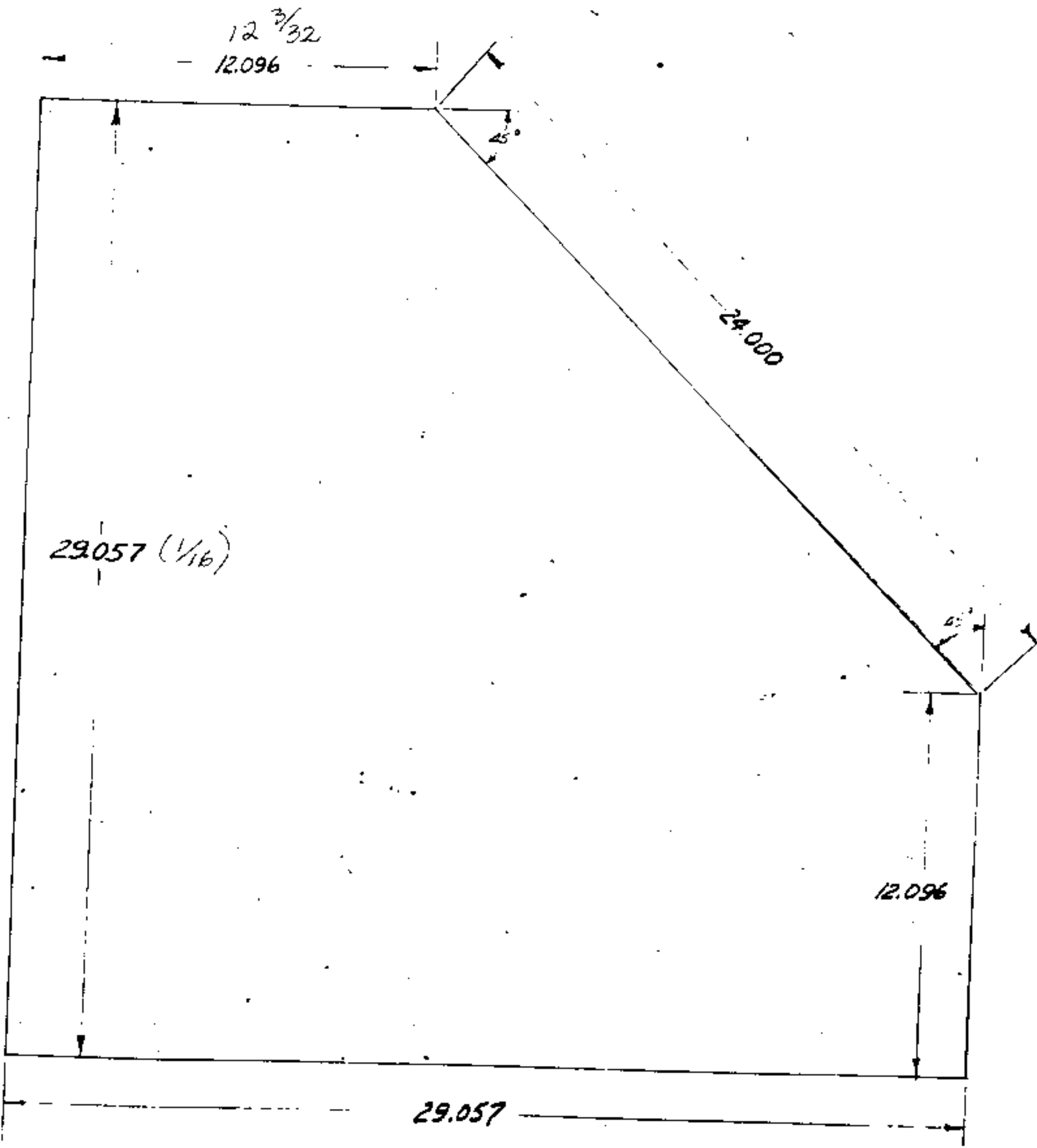

Sheet 3
5/2/45
g.f.d.

Part No. 2 - 1 Rqd.

Material $\frac{3}{4}$ " Plywood.

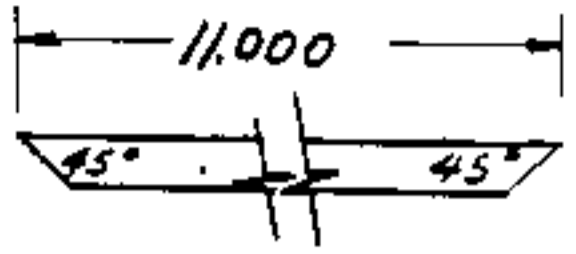
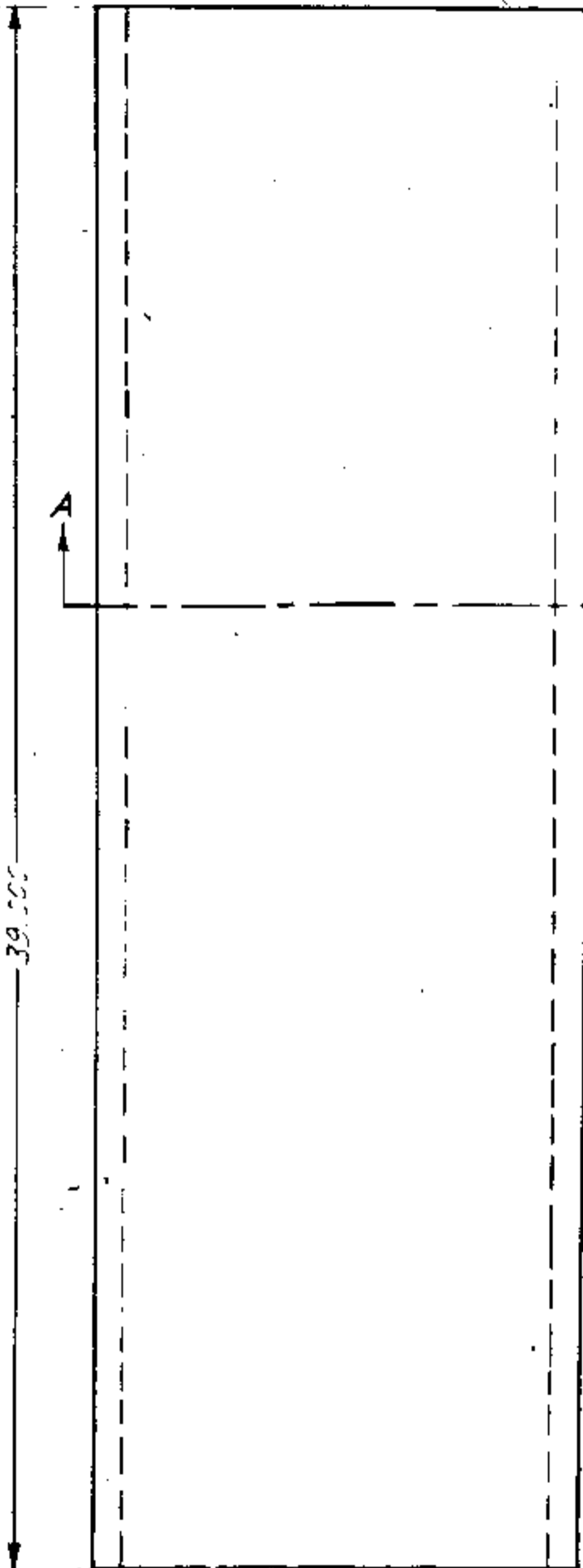

View A-A

Sheet 4
5/2/45
7th.

Part No. 3 - 2 Rqd.

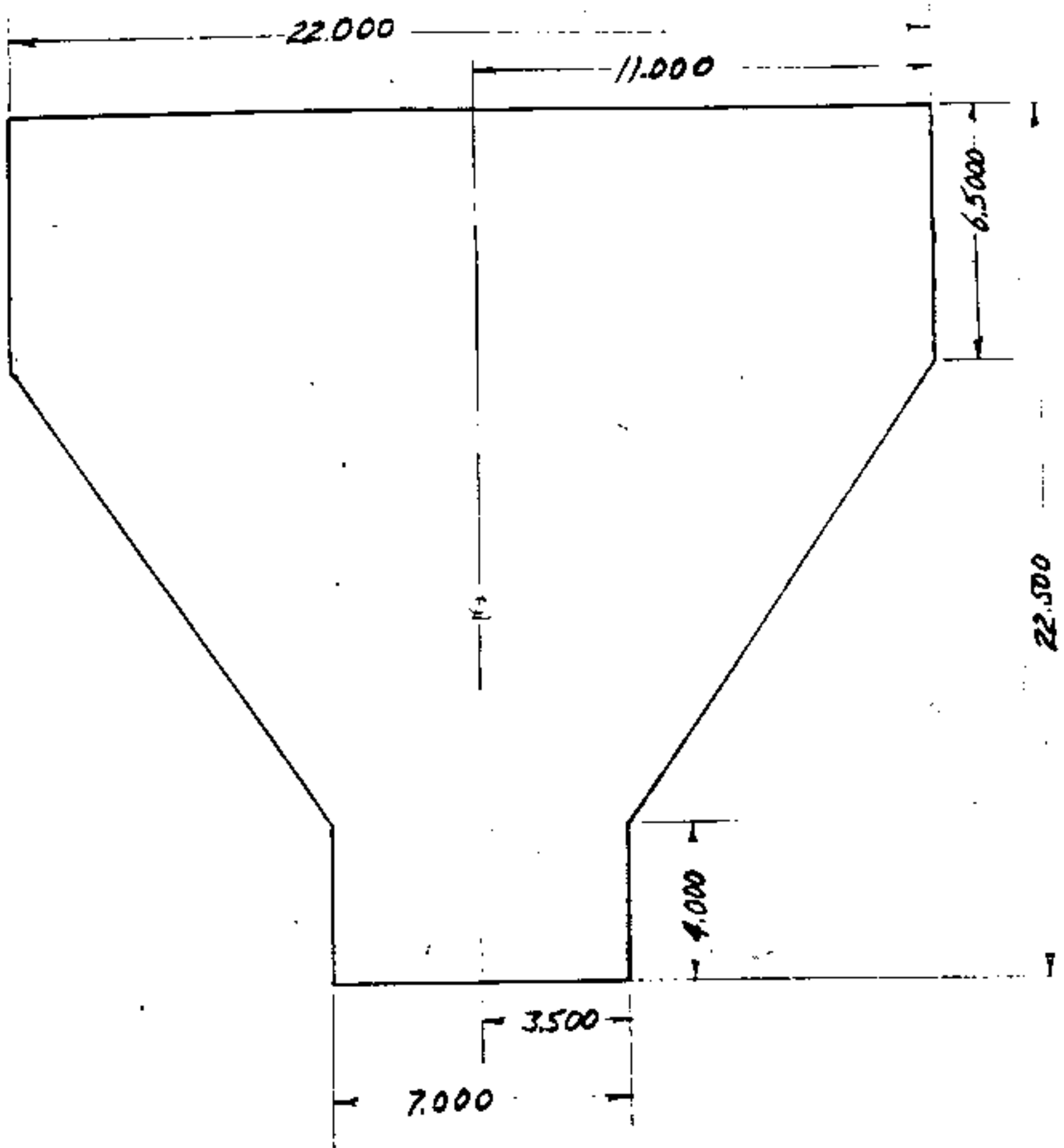

Material - $\frac{3}{4}$ " Plywood.

Sheet 5
5/2/45
y.t.d.

Part No. 4 - 1 Rqd.

Material - $\frac{3}{4}$ " Plywood

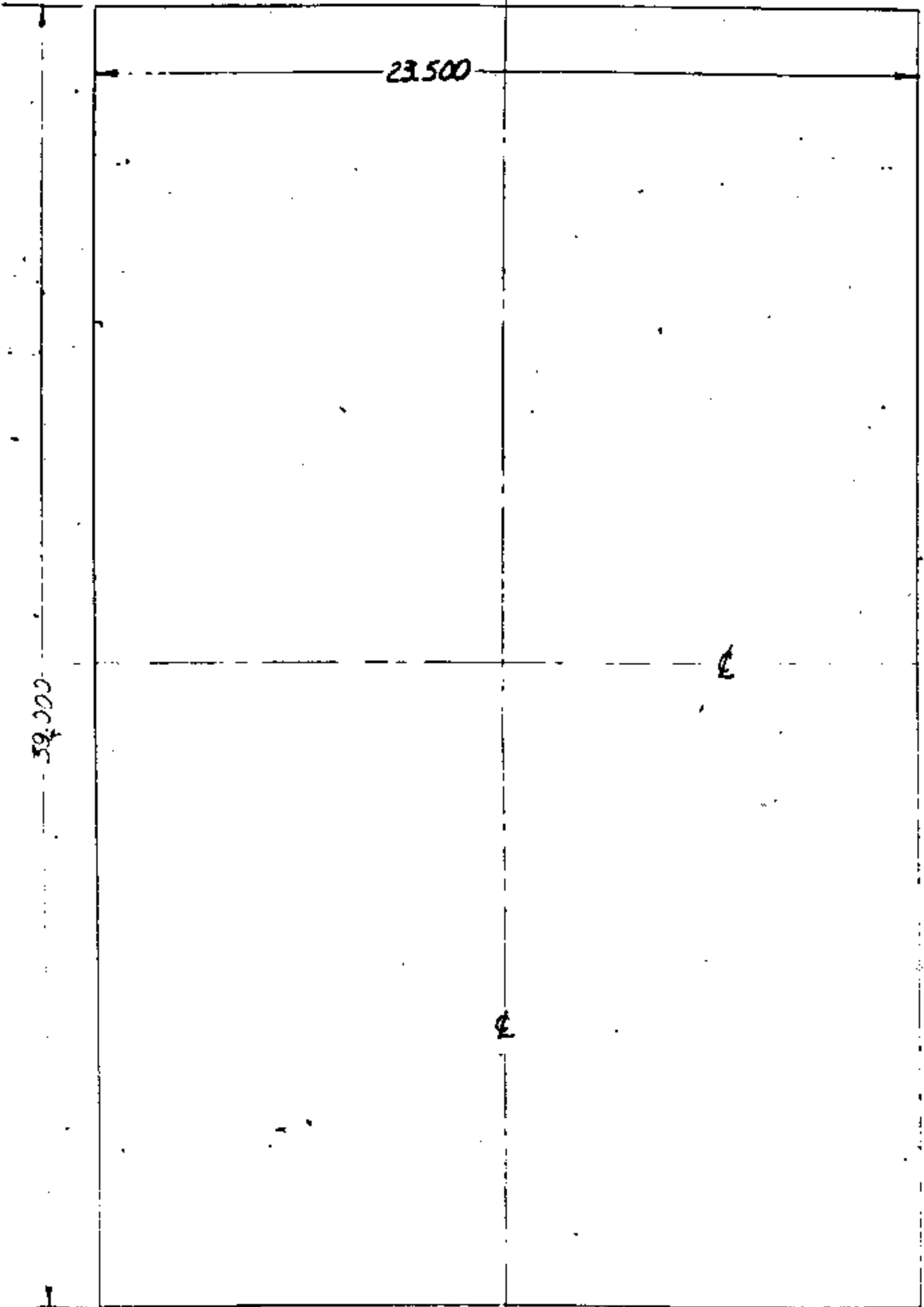

39.000

23.500

Sheet 6
4/13/45 J.F.

Part No 5-2 Rqd.

Material $\frac{3}{4}$ " Plywood

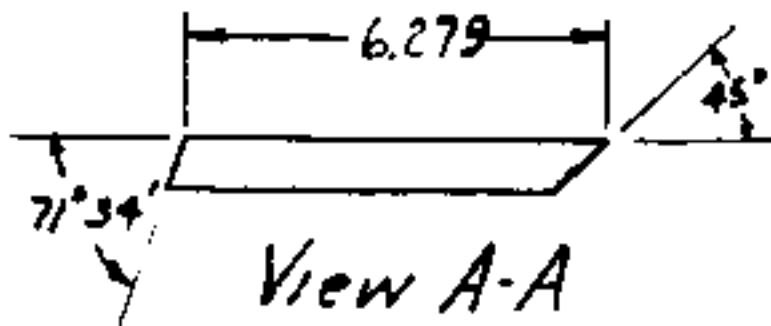
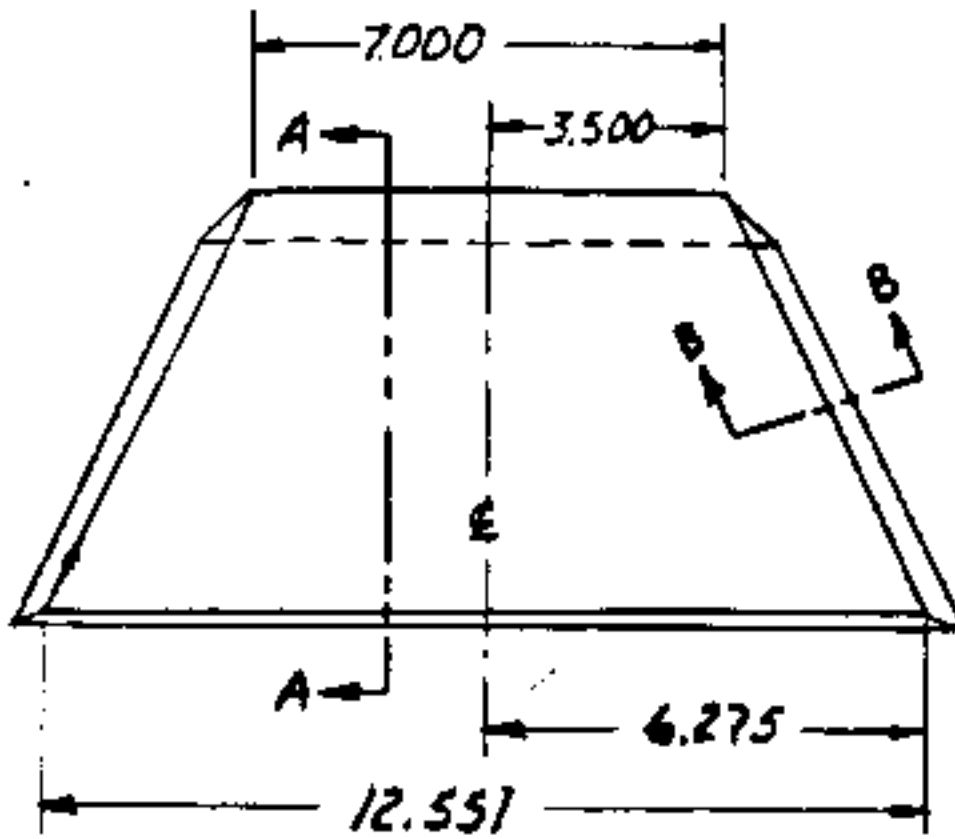

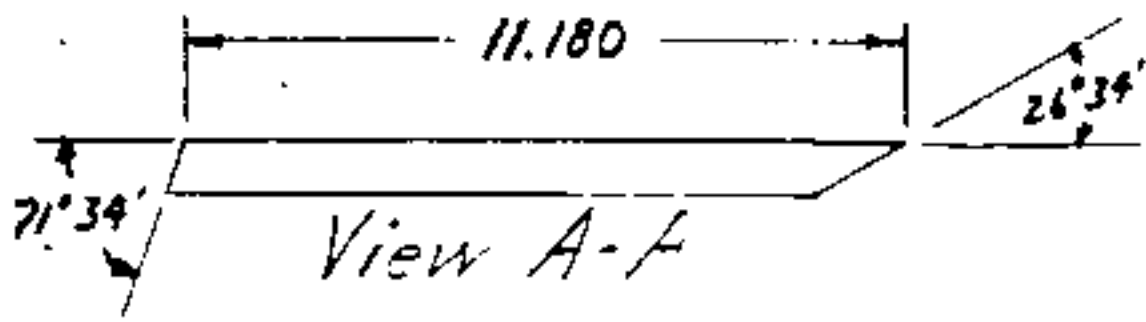
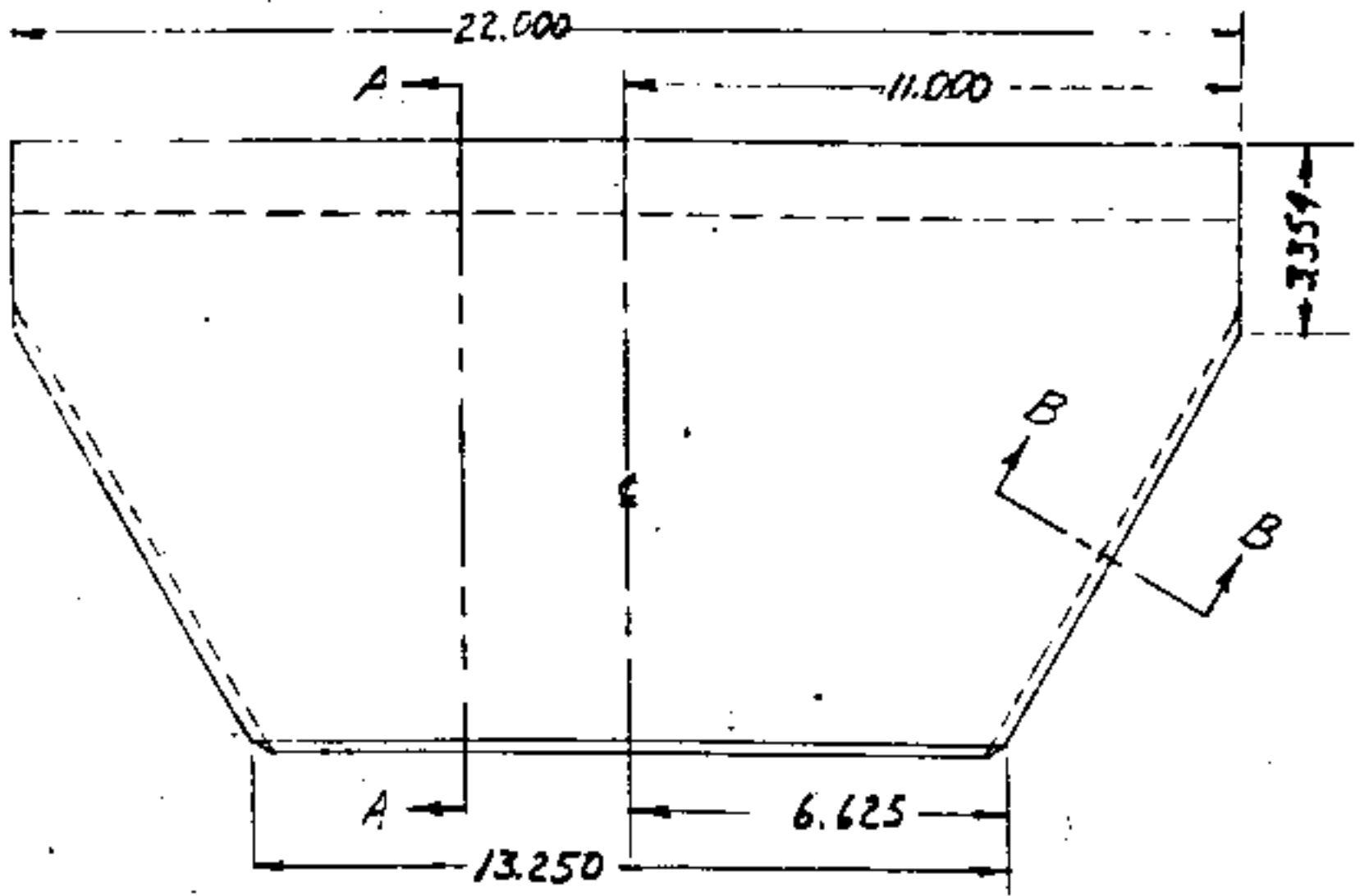

View A-A

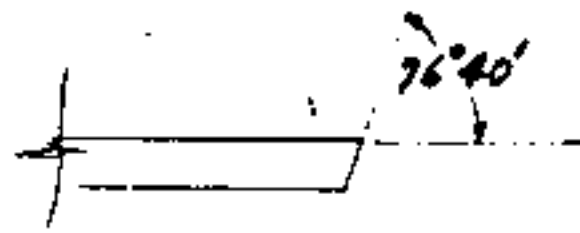

View B-B

Part No. 7-2 Rqd

Material: $\frac{3}{4}$ " Plywood.

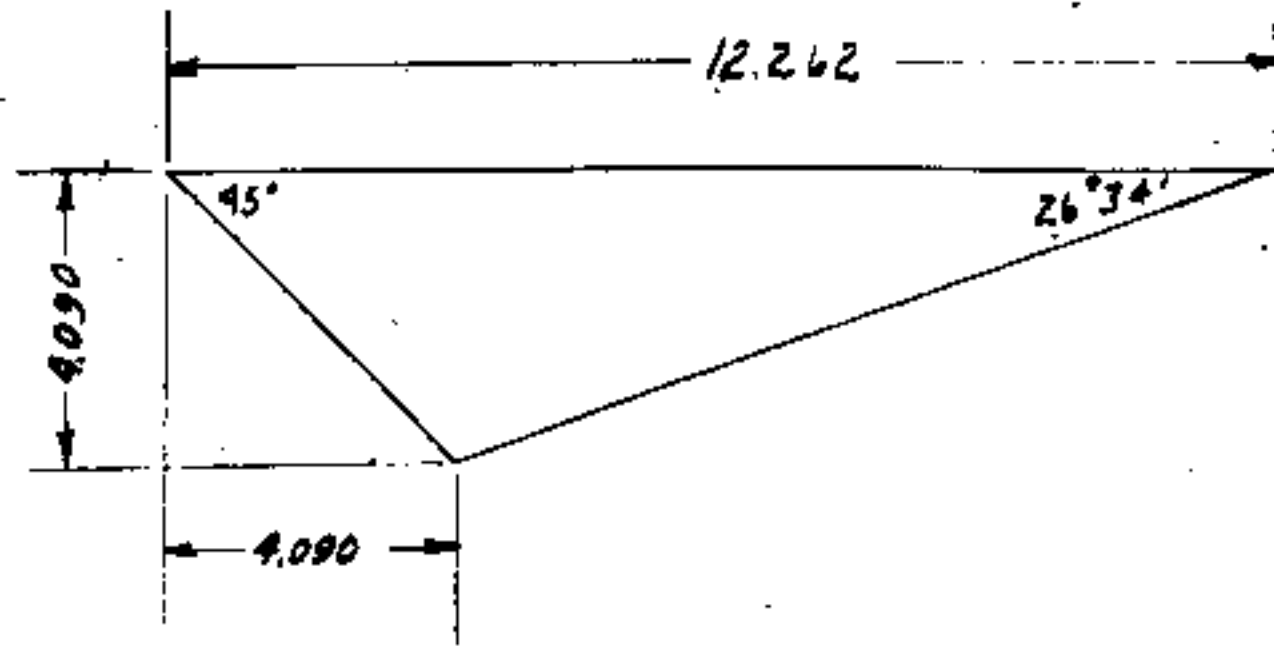

Sheet 9
5/2/15
J.F.D.

Part No 8 - 1 Rqd.

Material $\frac{3}{4}$ " Plywood.

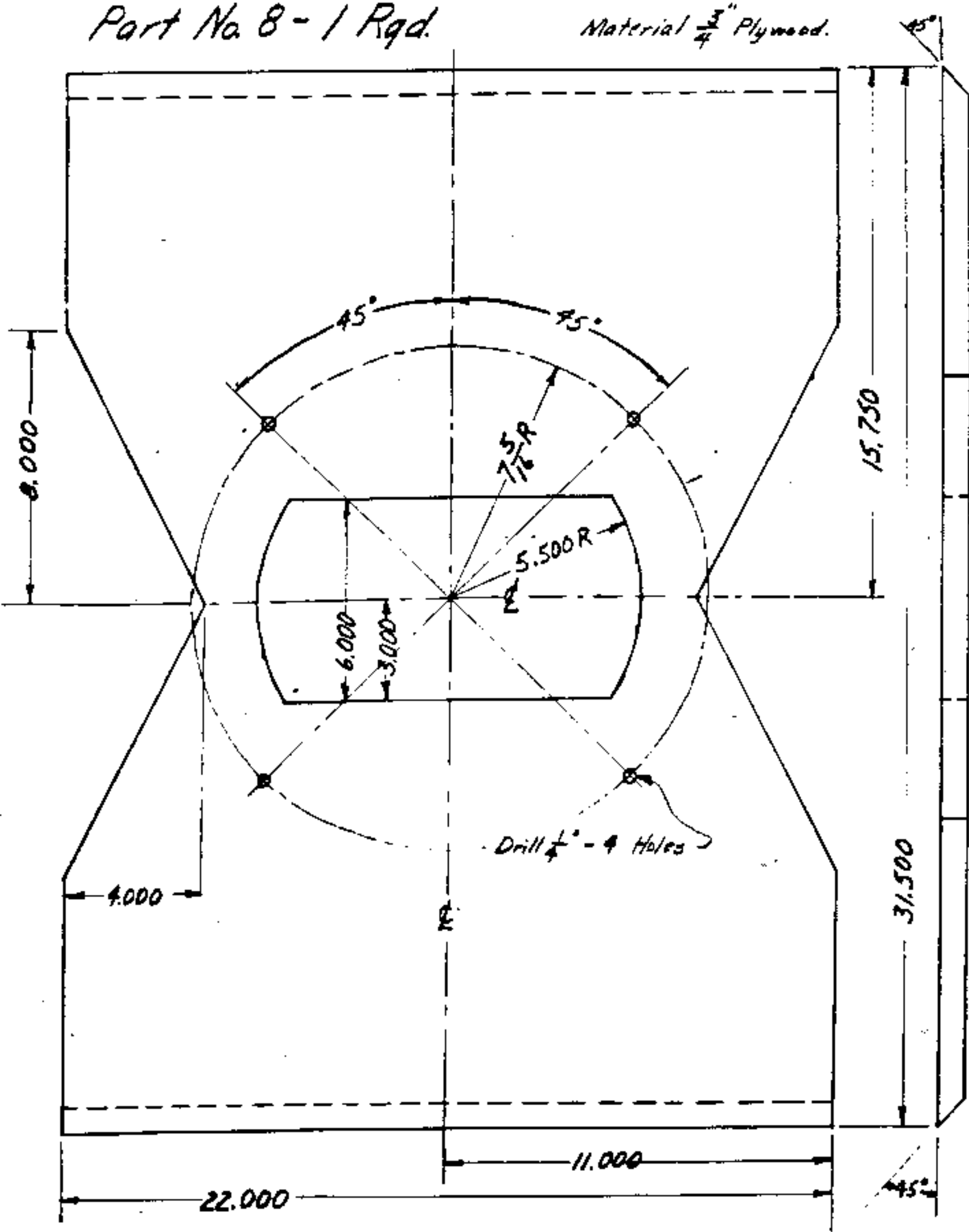

Sheet 10
15/01/00
J.P.A.

Part No. 9
4 Rqd.

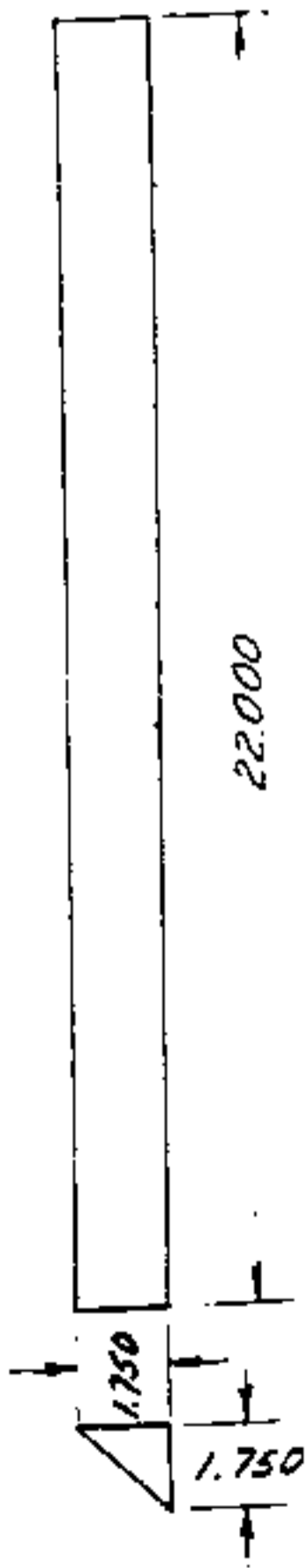

Part No. 10
2 Rqd.

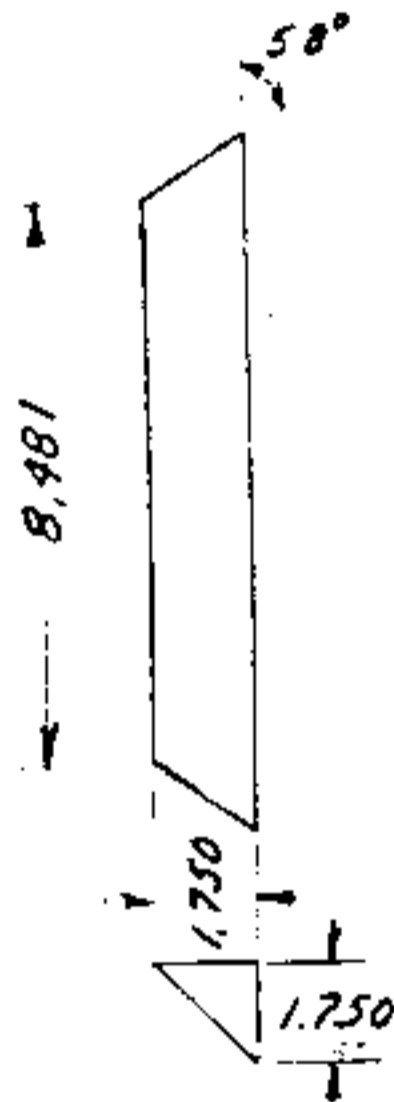

Sheet 11
9/14/95
gtd.

Part No. 11 - 3 Rqd.

Material $\frac{3}{4}$ " Plywood.

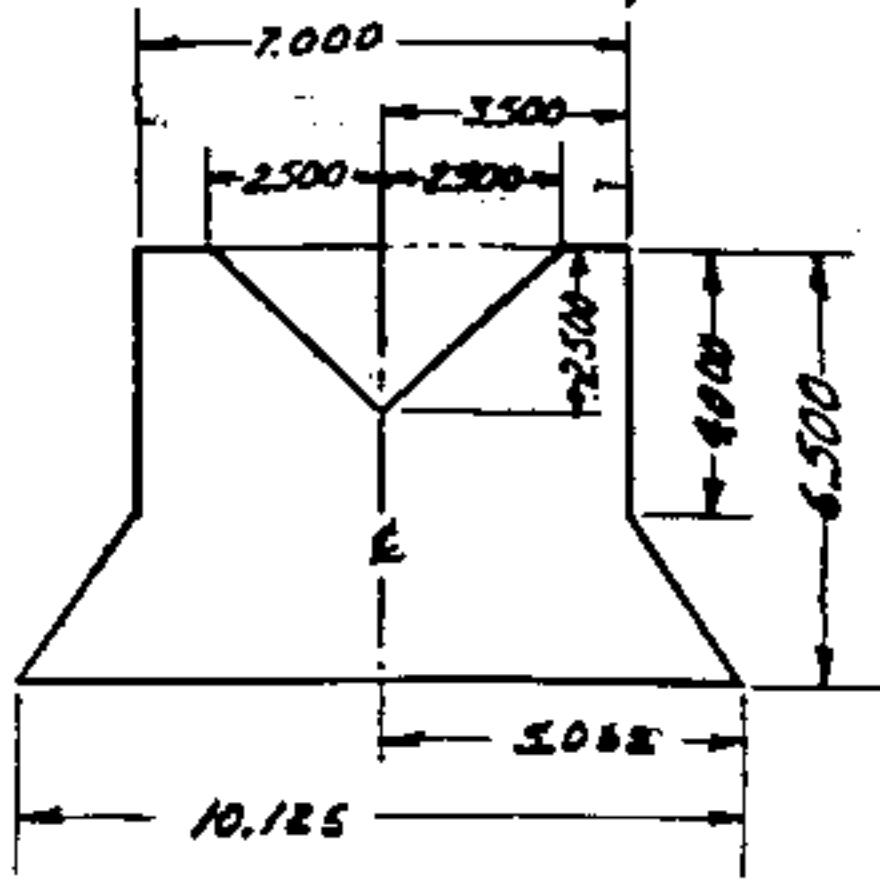

Part No. 12 - 1 Rqd.

Material $\frac{1}{2}$ " Plywood.

(Note: This part may be built up of two $\frac{3}{4}$ " thick pieces or three $\frac{1}{2}$ " thick pieces glued together.)

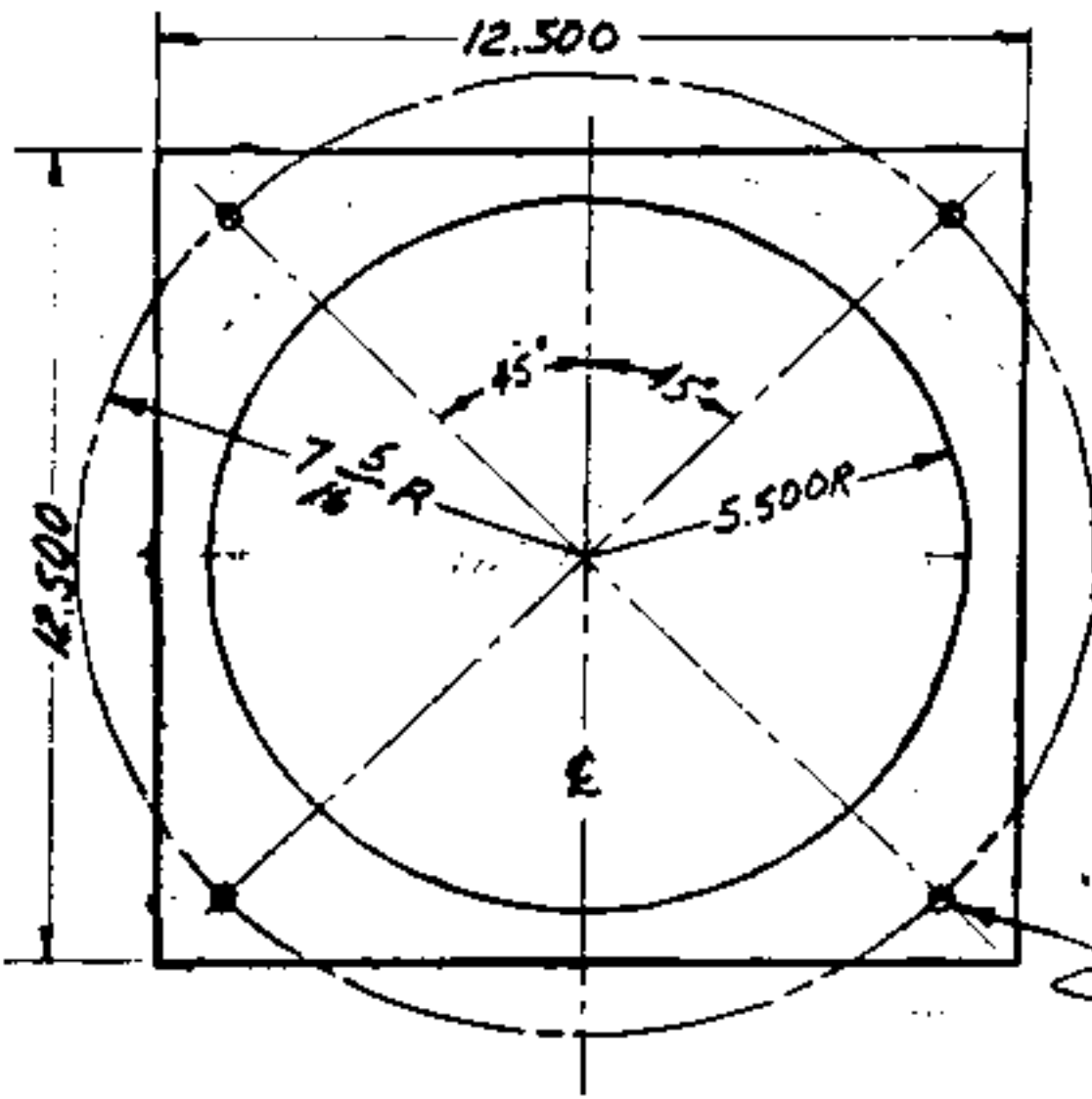

Drill $\frac{1}{4}$ " - 4 Holes

Sheet 12
11/10/46
9.7.8

Part No. 13 - 2 Rqd.

Material $\frac{3}{4}$ " Plywood.

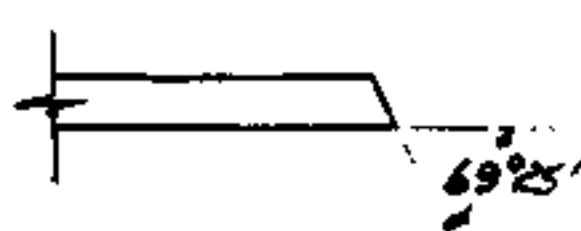
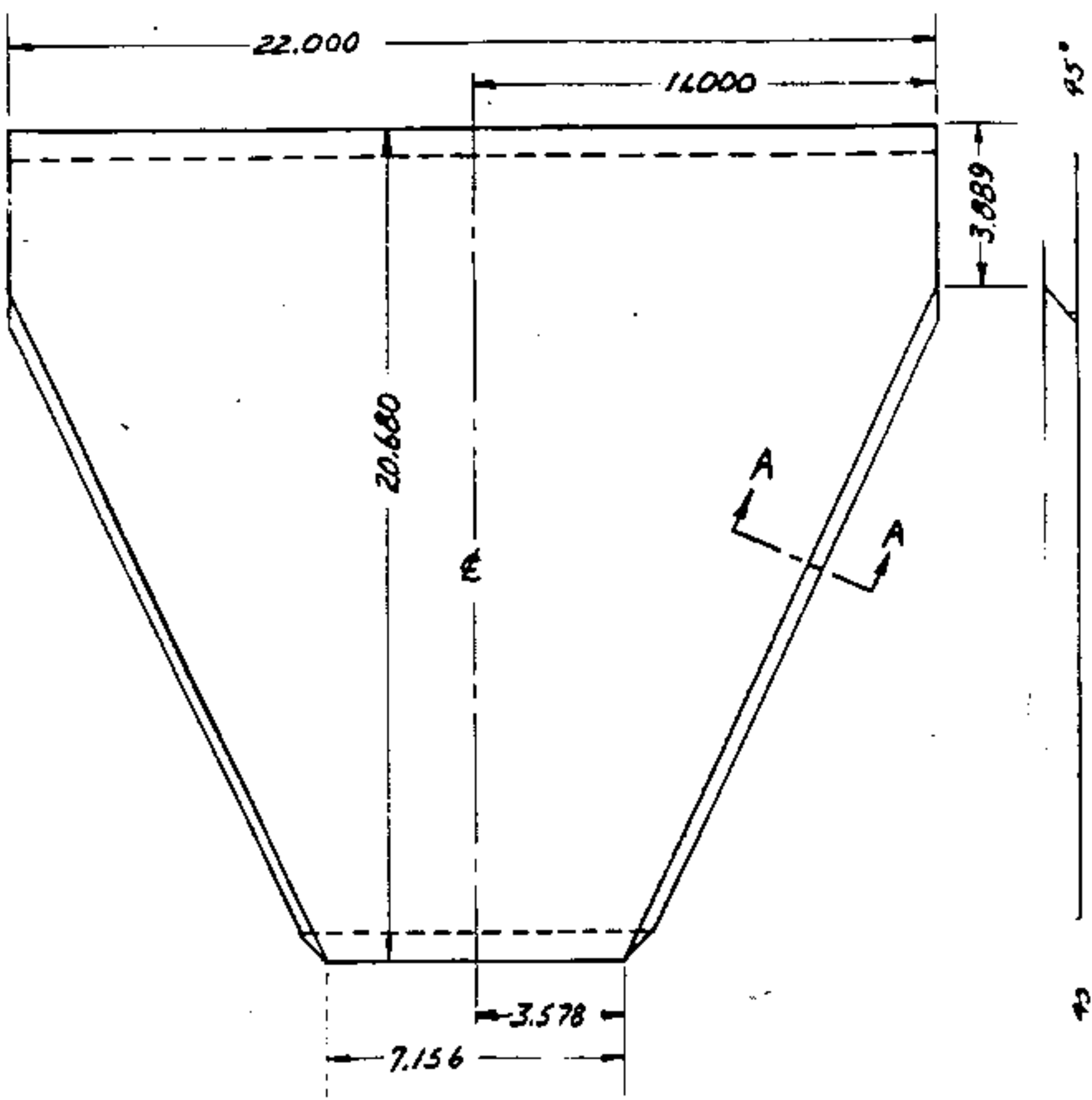

View A-A

Sheet 13
11/5/45
G. G. L.

Part No. 14 - 2 Rqd.

Material $\frac{3}{4}$ " Plywood

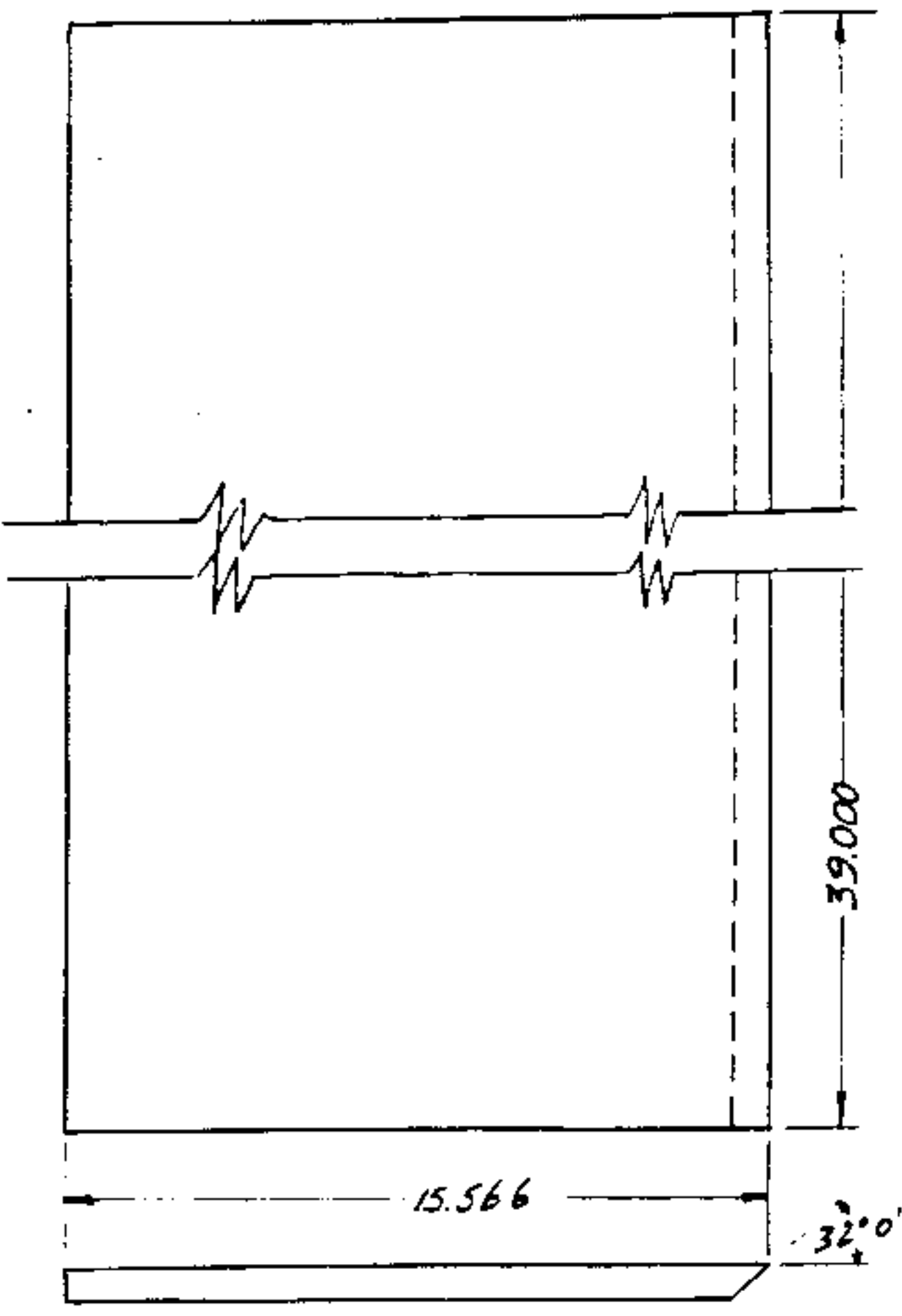

Sheet 14
10/2/45
J.F.L.

Part No. 15 - 2 Rqd.

Material $\frac{3}{4}$ Plywood

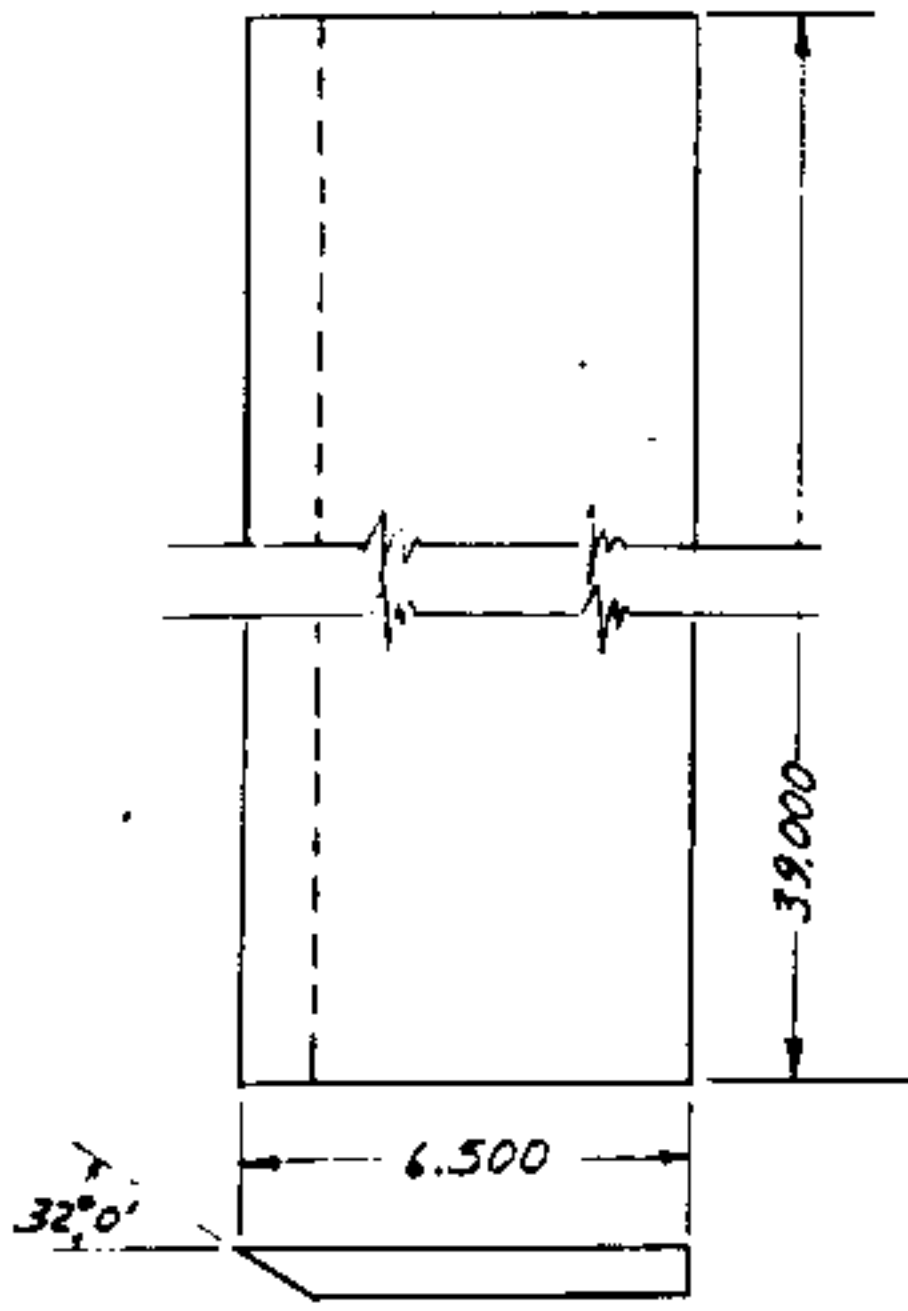

Sheet 15
5/2/46
G.F.L

Part No. 16 - 2 Rqd.

Material $\frac{3}{4}$ " Plywood.

(Note: This part may be made of $\frac{1}{2}$ " plywood)

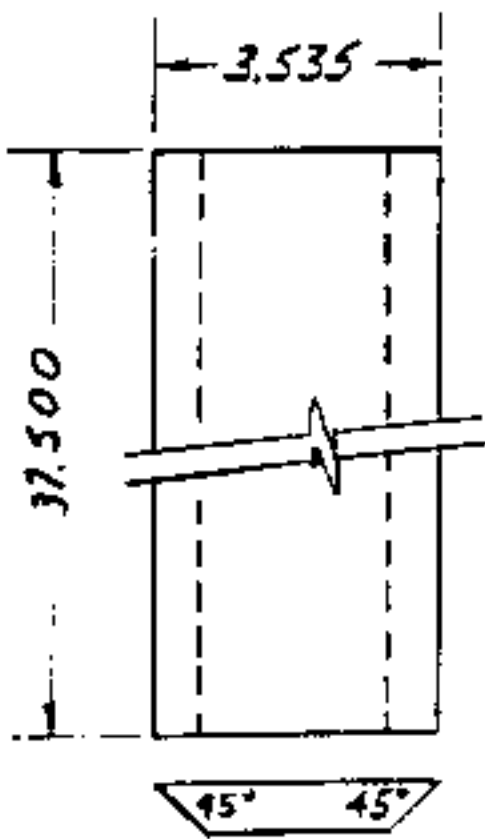

Part No. 17 - 2 Rqd.

Material $\frac{3}{4}$ " Plywood.
(Note: This part may be made of $\frac{1}{2}$ " plywood.)

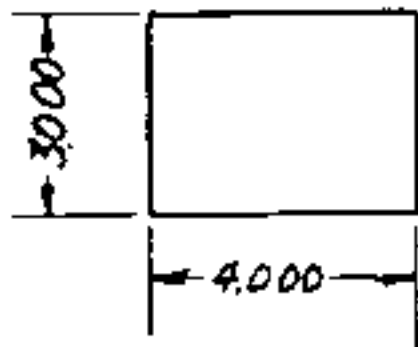

Part No. 18 - 4 Rqd.

Material: 3/4" - 1

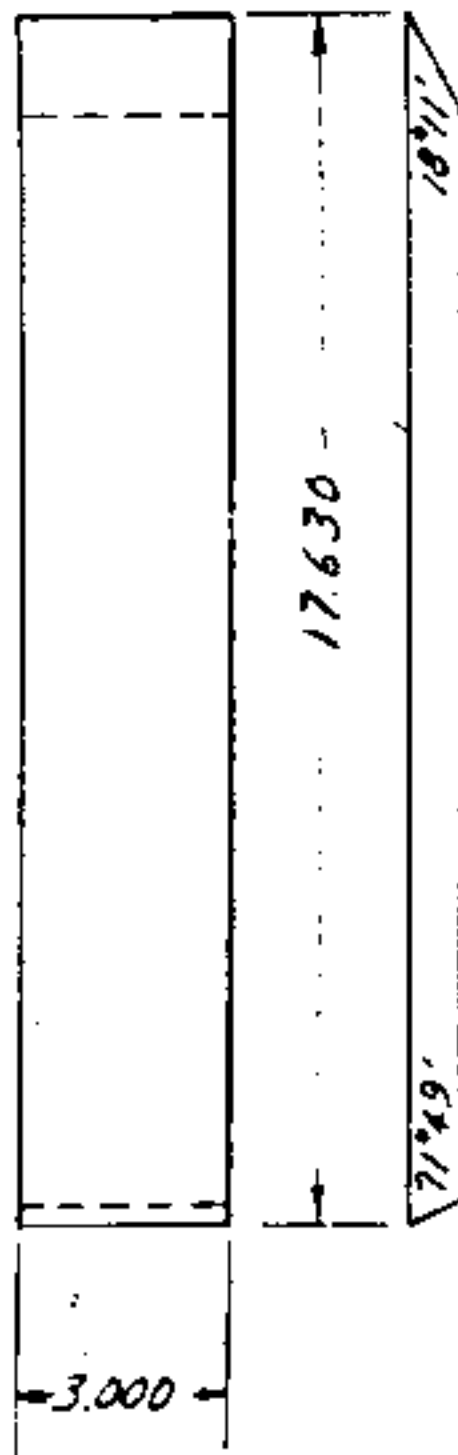

Part No. 19 - 2 Rqd.

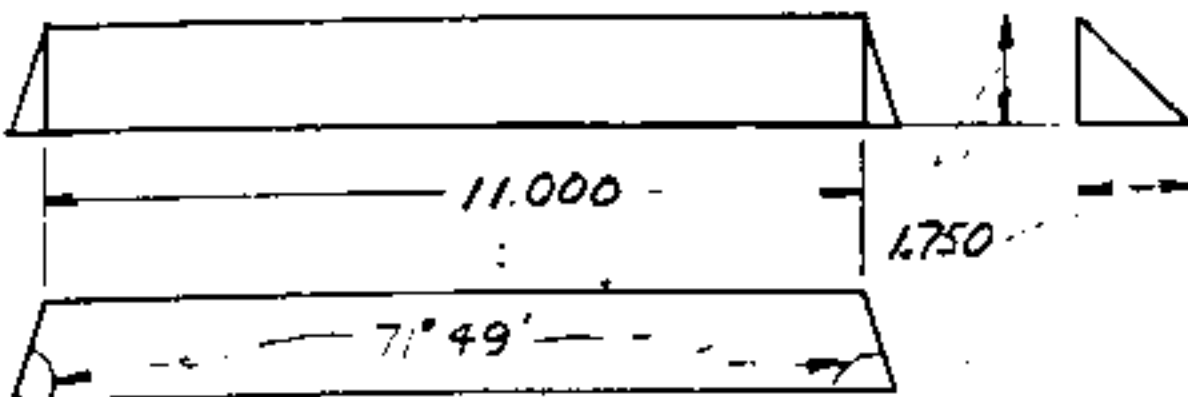

Sheet 17
9/14/45
92

"Cut-up" Sheet 1

$\frac{3}{4}$ " x 4' x 8' Plywood.

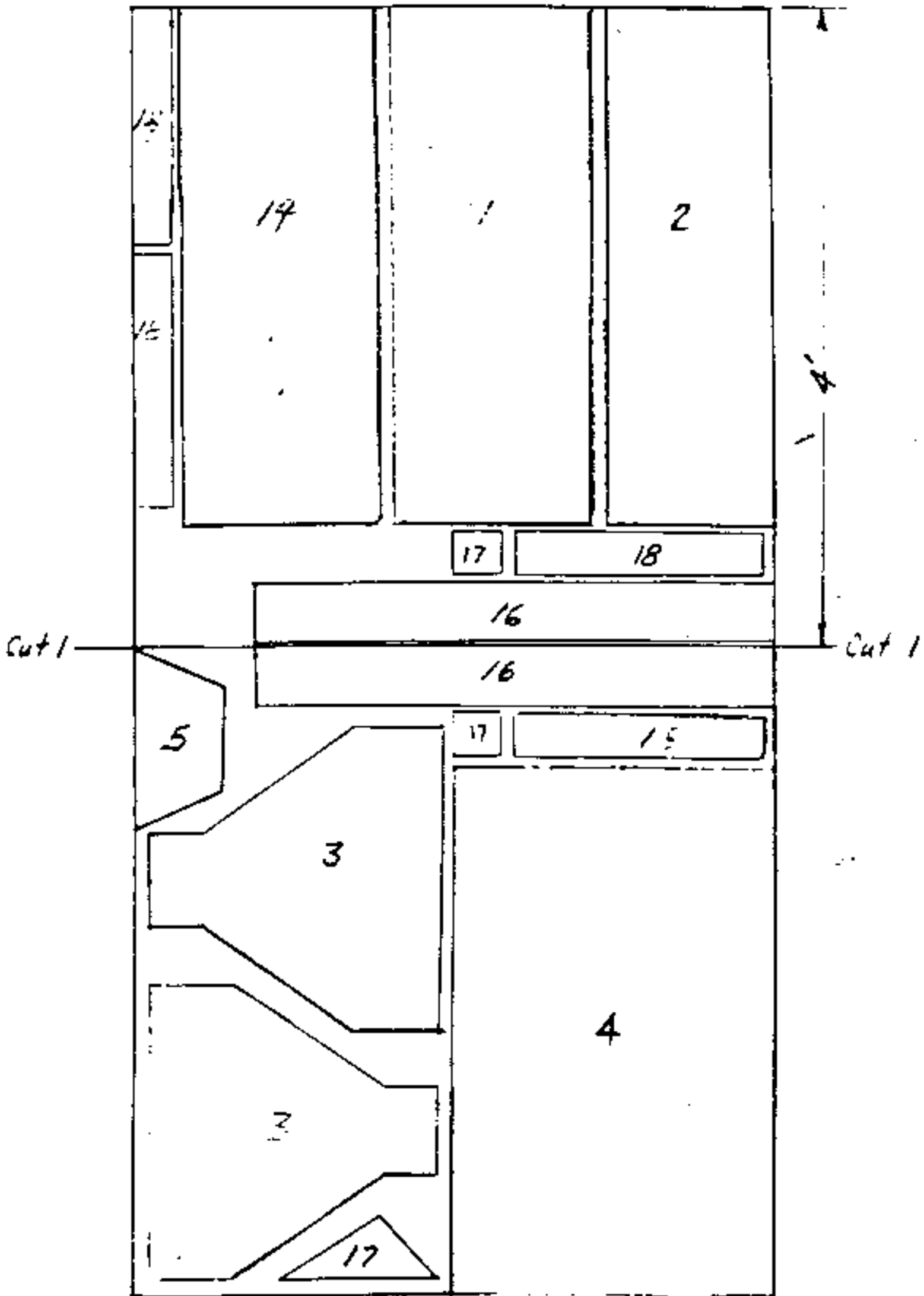

Sheet 1 B
12/7/45
J.T.L.

Cut-up - Sheet C

$\frac{3}{4}$ x 4 x 8 Plywood.

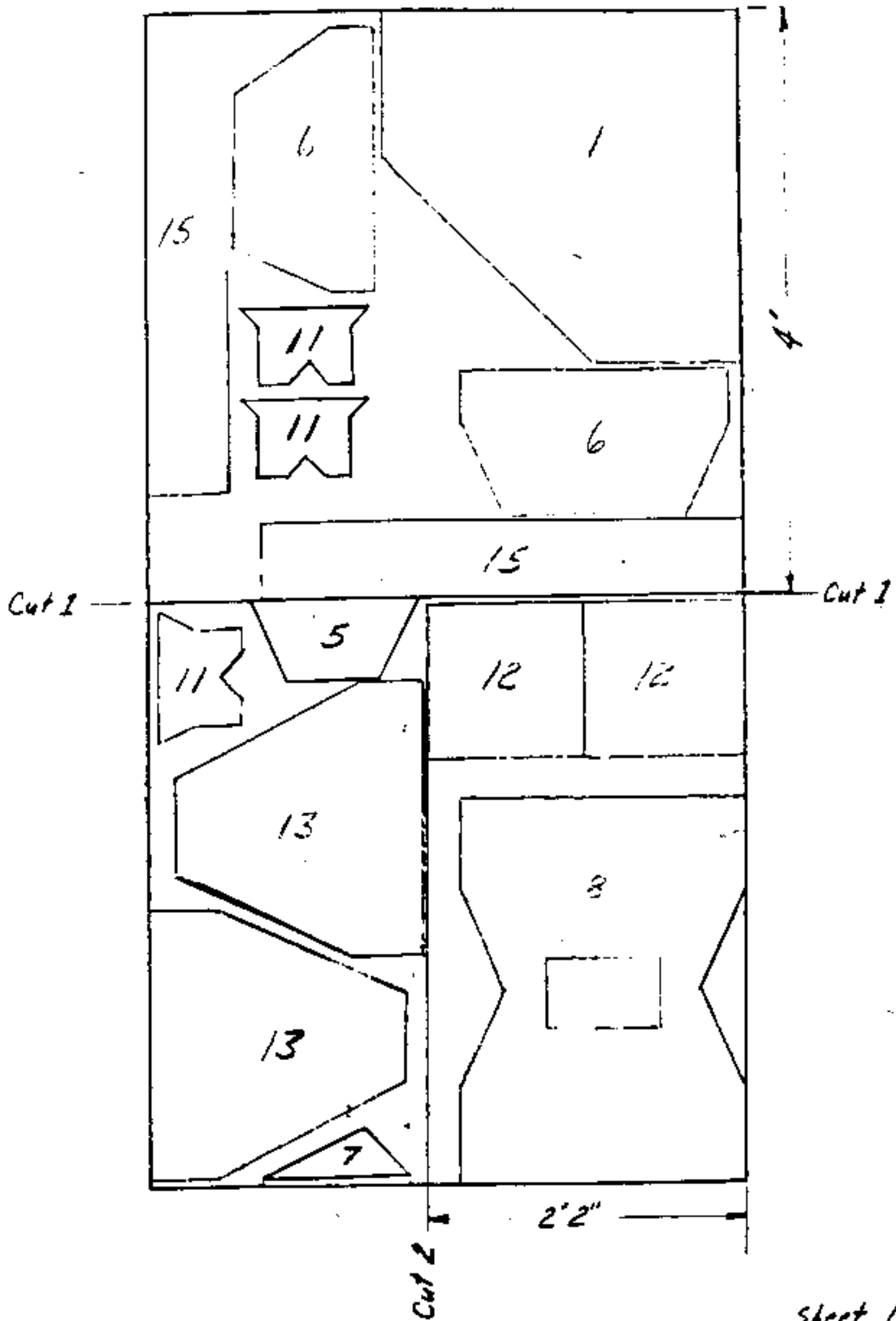

Sheet 19
12/7/45 g.f.l.

ASSEMBLY SEQUENCE;

1. Preparation of parts for assembly:

A. If piece 12 is made up of two $3/4"$ thick sheets, glue together to form a $1-1/2"$ thick piece. Glue a $1/2" \times 1/16"$ strip of felt on one side as shown in the sketch:

Note: Fill all holes or porosity so that this piece is air-tight from the center opening to the outside edge.

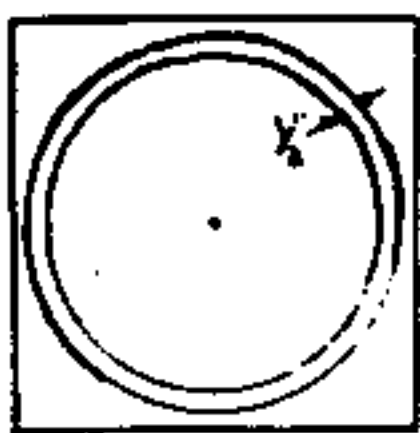

B. Counterbore the four $1/4"$ holes in piece 8 so that the nut of the $1/4"$ stove bolts will be below flush and insert four

$\#12 \times 3"$ machine screws as shown in sketch:



TITLE

Sheet 20

SCALE

97R

11/18/46

ASSEMBLY SEQUENCE:

2. Sub-Assemblies:

A. Top and Bottom (2 Required)

- 1) Screw and glue piece 7 to piece 3
- 2) Screw and glue piece 5 to pieces 3 & 7
- 3) Screw and glue piece 6 to pieces 3, 5 & 7

~~4) Screw and glue two pieces 4 to piece 3. Screw and glue pieces 4 in together.~~

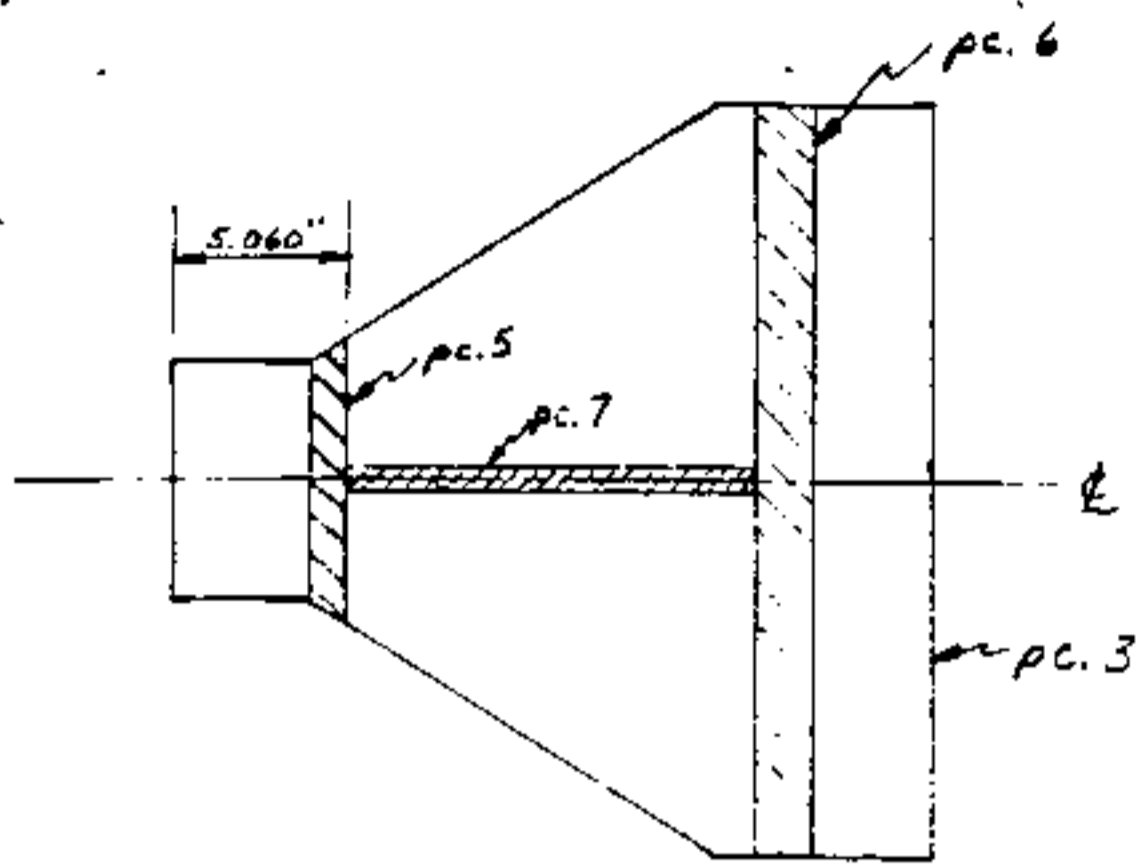

*cross-hatched area:
show locations at
which the various
parts fasten to
piece 3.*

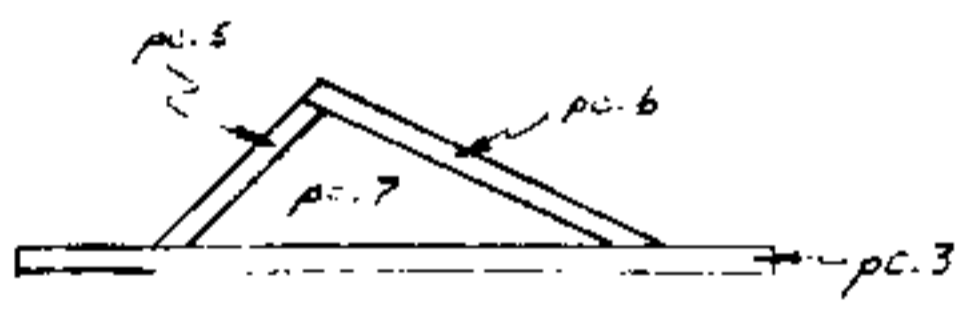

	TITLE
	Sheet 21
	SCALE
	12/7/92
	PRINTED IN U.S.A.

ASSEMBLY SEQUENCE:

2. Sub-Assemblies:

B. Front (1 required)---First Step

- 1) Screw and glue pieces 15 to piece 4 as shown on sheet 23.
- 2) Screw and glue pieces 19 to piece 4 in location shown.
- 3) Using pieces 15 & 19 as guides, screw and glue pieces 18 to pieces 4, 15 & 19.
- 4) Screw and glue two pieces 9 and pieces 17 to piece 4.

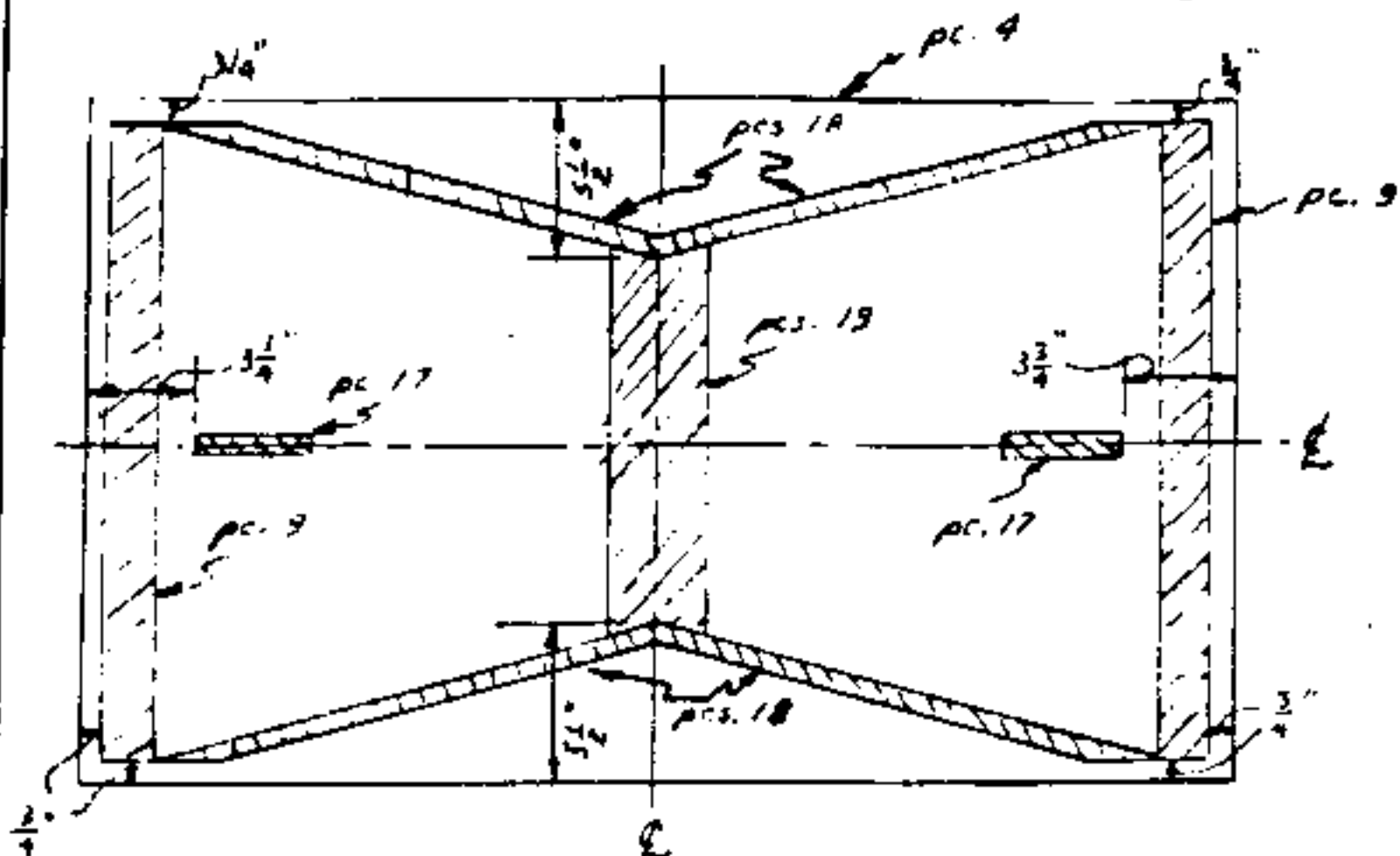

Cross-hatched areas show locations at which the various parts fasten to piece 4

Pieces 15 not shown. (see sheet 23)

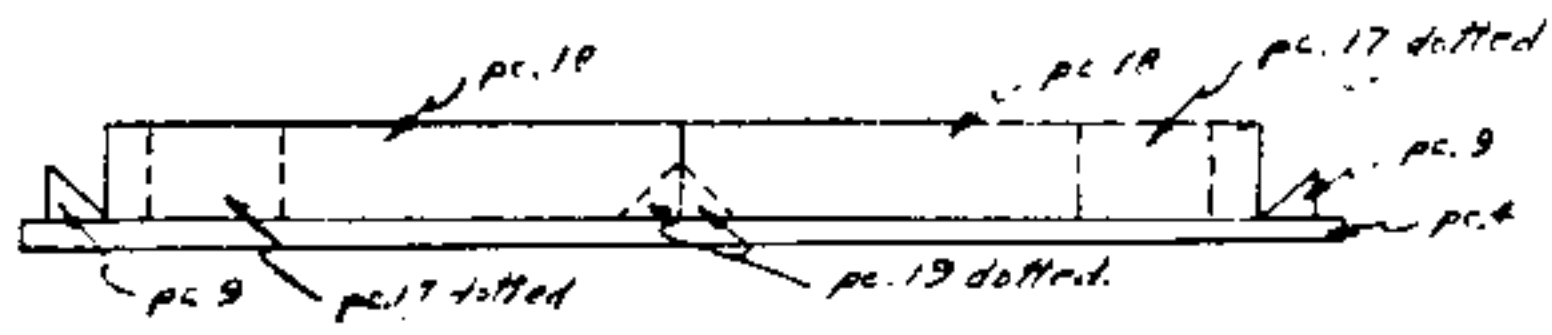

Sheet 22

28/9/45

PRINTED IN U.S.A.

pc 9

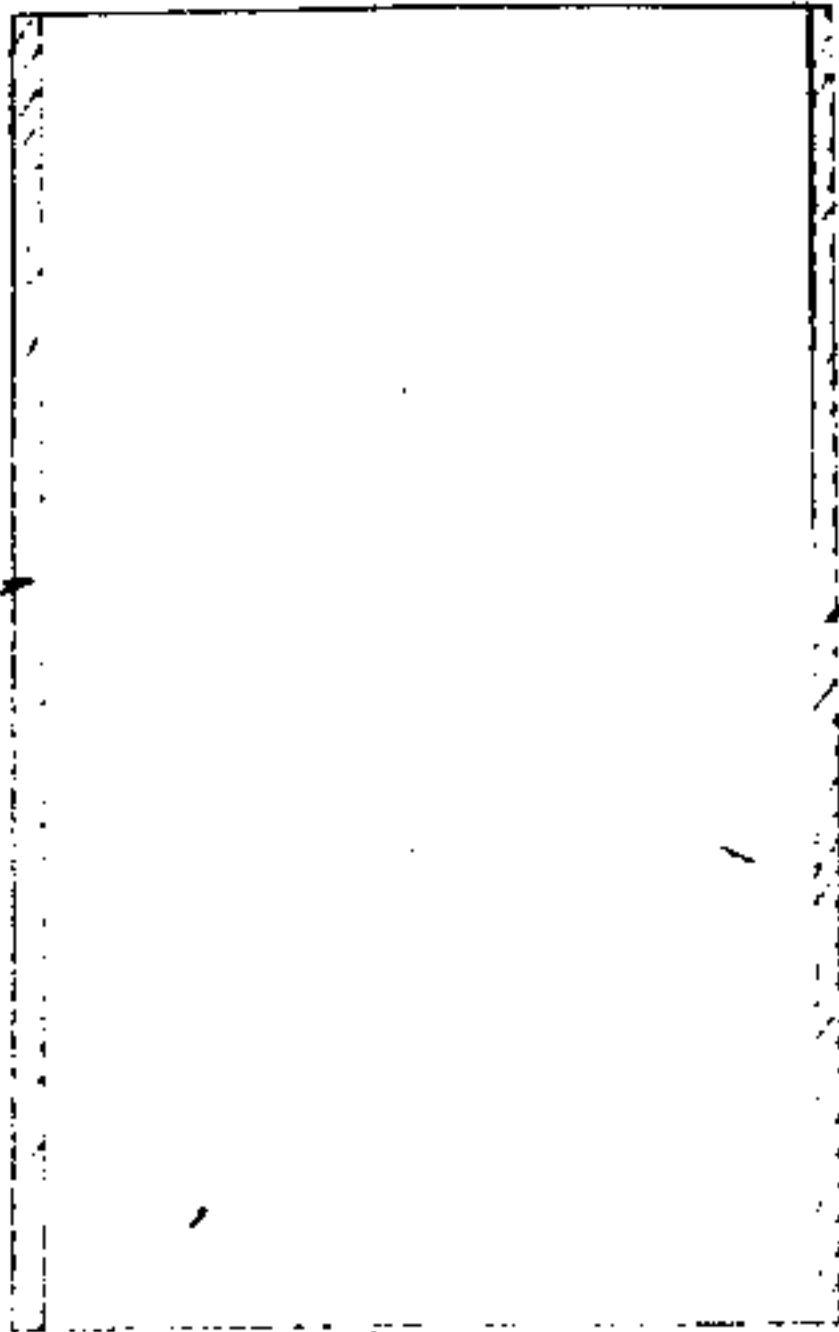

Cross-hatched area
 show in section 17
 which piece 15
 faster in piece 4

pc 15

pc 15



TITLE

Sheet 23

SCALE

7/14/73

PRINTED IN U.S.A.

ASSEMBLY SEQUENCE:

2. Sub-Assemblies:

C. Front--Second Step (1 Required)

1. Screw and glue piece 8 to pieces 17, 18 & 15 on Sub-Assembly B.
- 2.
3. Attach piece 12 to piece 8 by means of the four 1/4" stove bolts in piece 8 and four wing nuts. The side of piece 12 on which the felt is glued should be placed against piece 8.

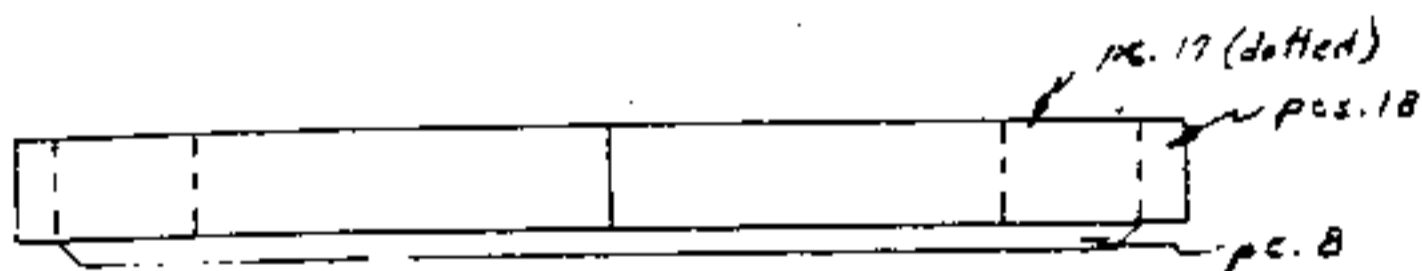
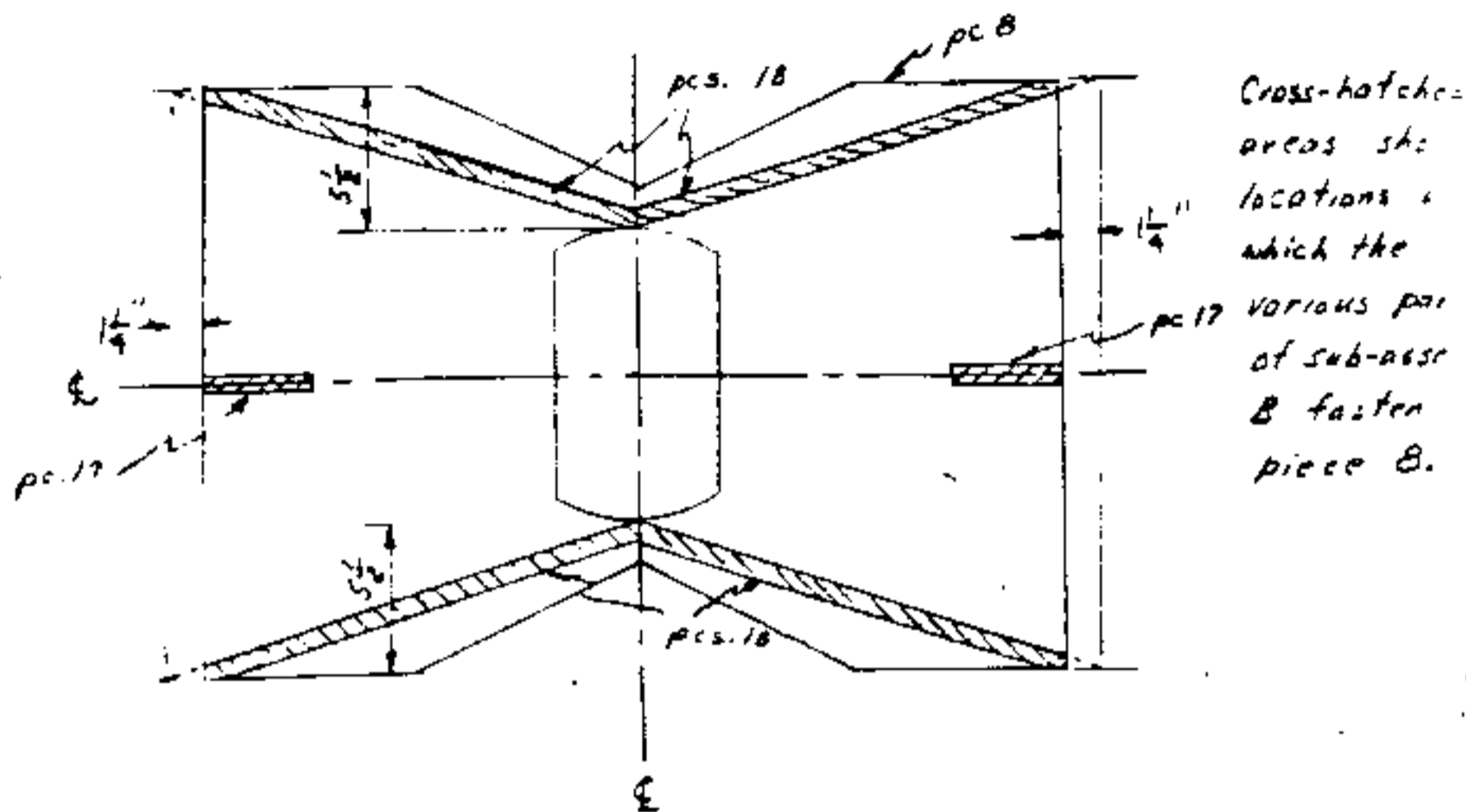

Note: Only pieces 17 and 18 of Sub-assembly B are shown in this sketch.

Sheet 24

11/5/45

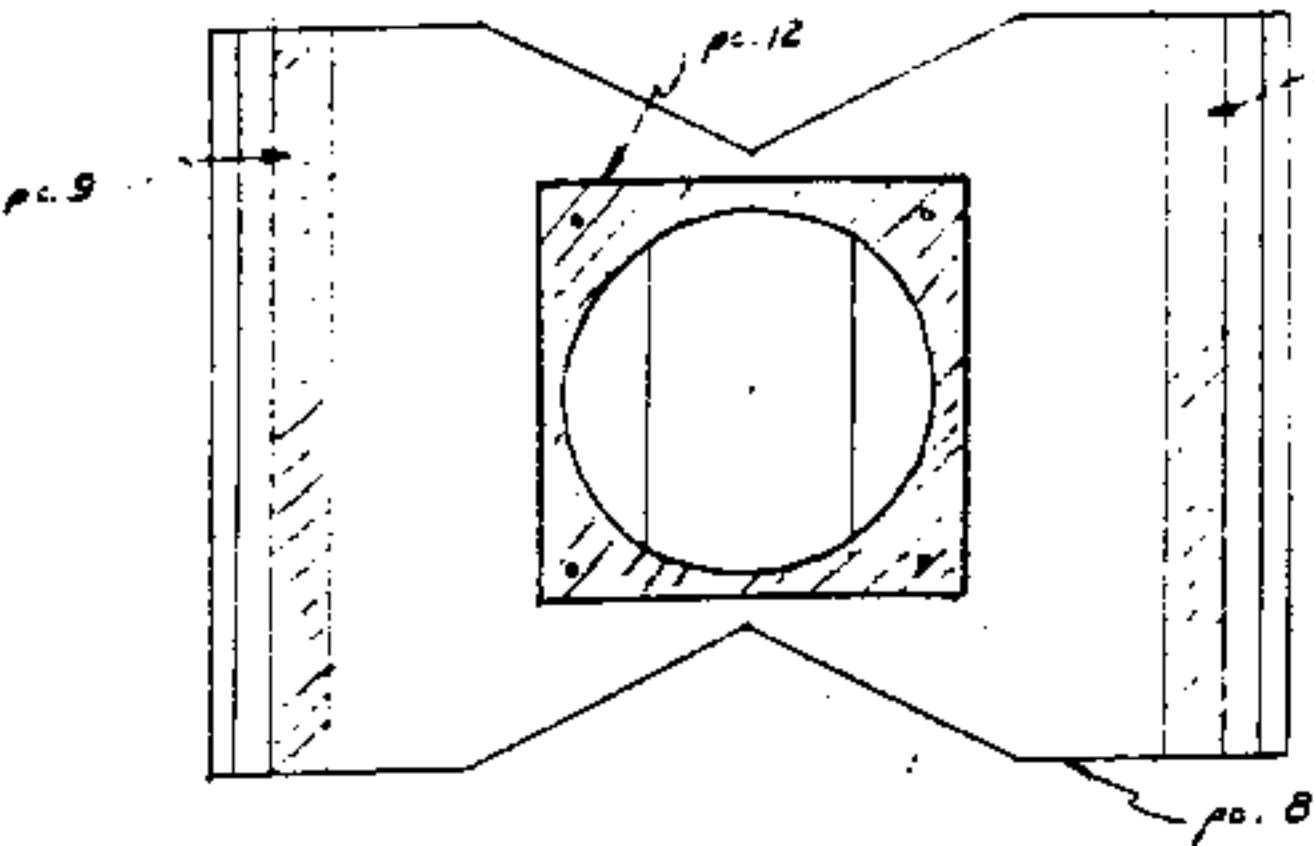

Cross-hatched areas show locations at which pieces 9 + 12 are fastened to piece 8. Location of piece 12 is determined by bolts in piece 8.

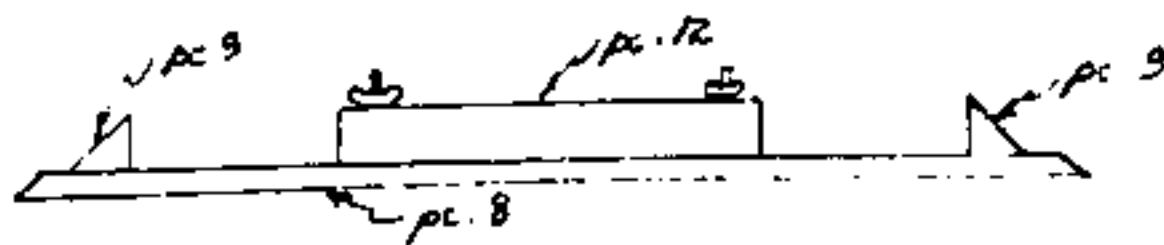

Note: Parts of sub-assembly B are not shown in this sketch for clarity.

Note: Pieces 9 are not attached at this time but approximate position is shown.

TITLE

Sheet 25

SCALE

11/5/45

PRINTED IN U.S.A.

ASSEMBLY SEQUENCE:

2. Sub-Assemblies:

D. Back Center (1 Required)

Screw and glue pieces 10 to one piece 11.

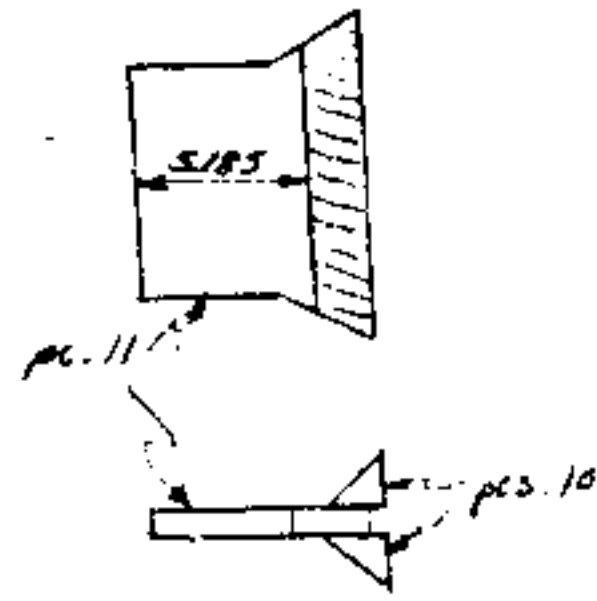

Cross hatched area shows location of which pieces 10 are fastened to piece 11.

B. Beck (1 Required)

- 1) Screw and glue the two remaining pieces 11 to the two pieces 16 as shown.
- 2) Screw but do not glue piece 2 to pieces 11 & 16.
- 3) Screw but do not glue Sub-Assembly D to piece 2.

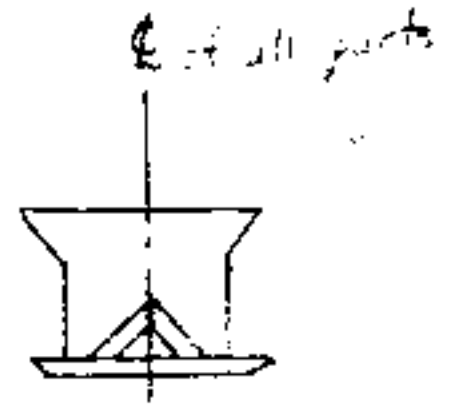
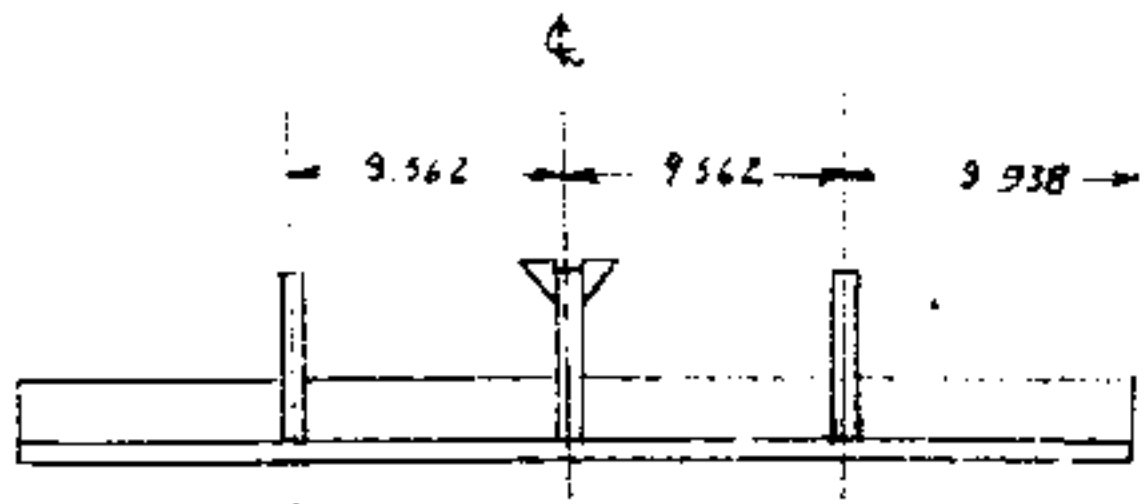
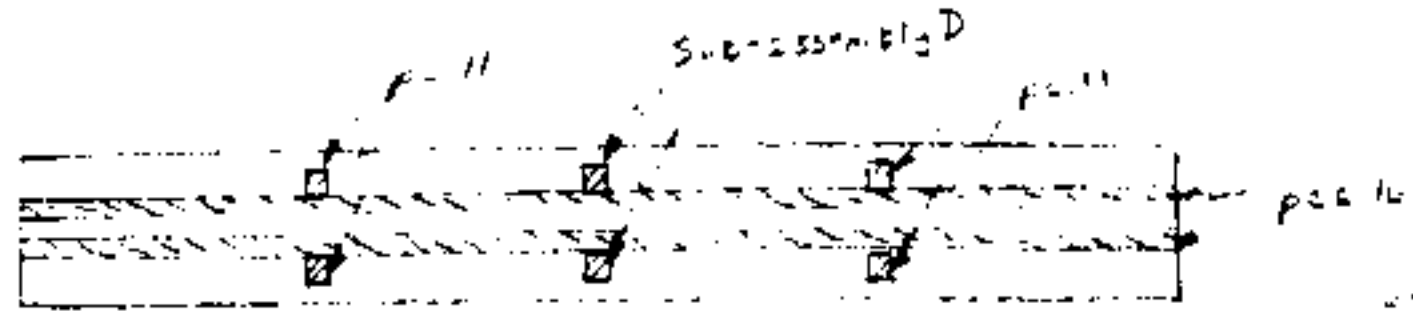

Sheet 26

12/7/45
PRINTED IN U.S.A.

ASSEMBLY SEQUENCE:

3. Final Assembly:

- A. Screw but do not glue Sub-Assembly A to pieces 4, 9 & 15 of Sub-Assembly C.
- B. Screw but do not glue Sub-Assembly E to Sub-Assemblies A.
- C. Screw and glue pieces 13 to pieces 10 & 11 of Sub-Assembly E and to pieces 8 of Sub-Assembly C and insert pieces 9 at the junction of pieces 13 and 8.

NOTE: - Due to the pile up of tolerances, pieces 13 may not fit perfectly. The following assembly method is recommended: Fasten pieces 13 firmly in place against pieces 10 & 11 of Sub-Assembly E; then, by pulling pieces 13 together or by pushing them apart at their junction points with piece 8, adjust so that Sub-Assembly E is undistorted. Fasten the pieces 13 to piece 8 in that position. Insert pieces 9. If necessary, the joint between pieces 8 and 13 may then be planed smooth.

- D. Remove all of Sub-Assembly E except Sub-Assembly D. Glue Sub-Assemblies A to Sub-Assembly C.
- E. Remove piece 2 from Sub-Assembly E and glue and screw the remainder to Sub-Assemblies A and D.
- F. Screw and glue one piece 14 to pieces 3, 5, 6, 10, 11, & 13.
- G. Glue strips of $1/2"$ x $1/16"$ felt to all the surfaces that the other piece 14 fastens against. This is important so that the various joints will be air tight when piece 14 is fastened in place.
- H. Screw but do not glue pieces 2 and 14 in place.

TITLE

SHEET 27

12/7/45

PRINTED IN U.S.A.

INSTALLATION:

1. Installation of Speaker:

Remove piece 14 and piece 12. Screw 12 inch speaker to side of piece 12 which has no felt. Bring leads to speaker out through the piece 14 that is glued to the assembly near the junction of pieces 13 with the center piece 11. The leads must be brought out in such a way that the air tight seal of the cavity in which the speaker is placed is not broken. A suggested way is to bring each lead out separately through bolts as shown in sketch. Replace pieces 12 and 14. See note below.

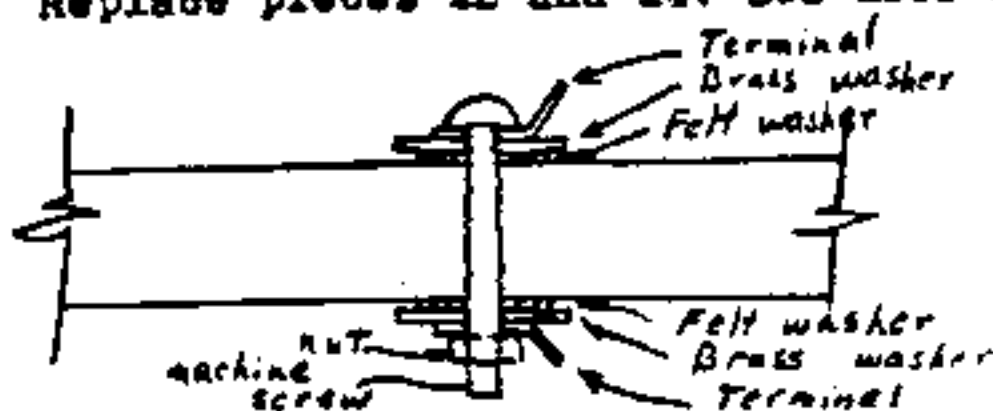

2. Fitting horn to corner of room.

Trim piece 2 to fit smoothly around the baseboard or any other projections or irregularities of the walls in the corner of the room in which the horn is to be installed. Piece 2 is removable to facilitate this trimming. After piece 2 is trimmed, glue a 1/4" thick felt or rubber strip along the two sides of piece 2 which abut the walls of the room.

To attach the top board, piece 1, attach three 2" angle brackets as follows: one on the back of piece 2 and one on each piece 15. Place the horn in the corner of the room and set piece 1 in place against the walls. Using this as a means of locating piece 1, screw piece 1 to the angle brackets.

NOTE: Be sure that space between speaker and piece 8 is perfectly air-tight, except for the throat opening through piece 8.

USE OF 15" SPEAKER:

To use a 15" speaker in this horn in place of the 12" speaker specified, proceed as directed above except that when installing the speaker, mount the speaker directly to piece 8 and omit piece 12 entirely.

TITLE

~~Sketch~~

SCALE

11/18/46

PRINTED IN U.S.A.